



Part No. 2320-0164



MEK2002

REVISION 0

Trigger-Lock Mounting Kit - Polished MS Gauntlet Fairing HD XL 883L Super Low 2011 - 2014

Aluminum parts are electrocoated (E-coated) for durability and weather resistance.

Before assembly, read Warnings inside



WARNING

1. During installation, make sure that the fairing and hardware do not interfere with any cables or wiring when the forks are turned all the way in either direction. Also make sure, through the full range of adjustment, that the fairing and hardware do not hit the gas tank.
2. This is a detachable fairing, ALWAYS make sure the locking mechanism is fully engaged after installing the fairing.
3. The improper installation of this kit and related components could result in serious injury or death.



CAUTION

1. Memphis Shades fairings are made from Lucite® acrylic, and will last for years with proper care. Clean your fairing with plenty of soapy water (mild dishwashing liquid is best) and a soft cotton cloth. Use your bare hands to feel and dislodge bugs, or cover with a wet, soapy towel and let it soak. Don't use paper towels and scrape with anything. Small scratches can be removed with NOVUS #2.
2. Never use any glass cleaning products, petroleum based chemicals, or cleaning agents with ammonia, bleach or any other harsh chemicals. This includes (but not limited to) RainX, brake fluid, acetone, paint thinner, benzene and gasoline. "If it hurts your nose, it will hurt the plastic."
3. Glass cleansing agents will cause severe damage to your fairing, and will void your warranty. For care and cleaning we recommend using **Memphis Shades All Kleer**, a unique cleaner/polish, bug remover and rain repellent that leaves a super slick surface that makes the next cleaning even easier.
4. At certain times of the day the Sunlight can reflect off the curvature of a fairing and cause extreme heat build-up on motorcycle instruments and instrument panel. Take care when parking. Park facing the sun, place an opaque object over the instruments or adjust the fairing to avoid reflections.

1. Kit Contents

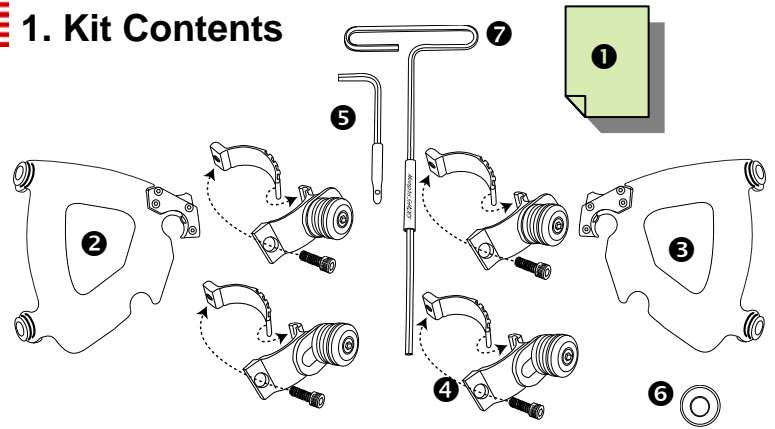

Ref	Code	Description	Qty
①	I2002	Mounting Instructions	1
②	M1558EC	Clutch side mounting plate	1
③	M1559EC	Throttle side mounting plate	1
④	S1215EC	Small detachable clamp assembly	4
⑤	M310	Short arm allen wrench, 3/16	1
⑥	M1603	Top mount headlight spacer	1
⑦	M314	T-Handle Wrench, 3/16	1

2. Mounting Instructions

Additional tools required that are not included in this kit. 7/16"(11mm), 1/2"(13mm), 9/16"(14mm) wrench & 3/4"(19mm) socket.

1. **Cover gas tank and front fender with towels to avoid damage during installation.**
2. Slide rubber boot off clutch cable adjuster - Located about halfway along clutch cable by front frame downtube. (Fig. 1)
3. Holding the cable adjuster with a 1/2 in wrench, loosen jam nut with a 9/16 in. wrench. Back jam nut away from cable adjuster. Move adjuster towards jam nut to allow free play at hand lever.
4. Remove retaining ring from pivot pin groove at bottom of clutch lever, and remove pivot pin. Remove clutch hand lever from bracket.
5. Re-route the clutch cable to inside of handlebars (Fig. 2)
6. Reinstall clutch lever, pivot pin and retaining ring, then turn cable adjuster away from jam nut until slack is eliminated at hand lever then tighten jam nut.
7. Remove snap plug on top of headlight bracket, then remove nut with 3/4" socket. Removing headlight housing.
8. Install the top mount headlight spacer ⑥ on headlight housing stud then reinstall headlight housing onto the headlight bracket, tightening nut and reinserting the snap plug.

Memphis Shades warrants all product components, metal and plastic, against defects in materials and workmanship for 24 months.

For Parts and Warranty Help, Contact:

Memphis Shades, Inc.

P.O. Box 429

Rossville, TN 38066

(901) 853 0293

Visit us on the web at www.memphisshades.com or you can also reach us by email:

customerservice@memphisshades.com

2. Mounting Instructions, continued

9. Install the Mounting plate assemblies ② and ③ onto the fairing, using the bolts that are pre-assembled on the Mounting plate assemblies.

The Santoprene grommets should be inserted through the holes in the fairing so that the flat round part of the grommet lies flat on each side of the plastic. Tabs point in towards the headlight. (Fig. 4)

10. Loosely install the four Fork Clamps on the forks, approximately 2" apart. (Fig. 5)

11. Start with Fork Clamp Bushing adjusted to the rear of the slot (Fig. 5) Then adjust as needed and check for clearance. (See warning above.)

12. Slip the mounting plates and fairing onto the fork clamps, (Fig. 7) while guiding the bezel over the headlight (Fig. 4) and secure the left and right side locking mechanism

13. Adjust the height, angle and alignment of the fairing and tighten **ALL** bolts.

Note: This is a detachable fairing, ALWAYS make sure the Locking Mechanism is Fully Engaged after installing the fairing! (Fig 8)

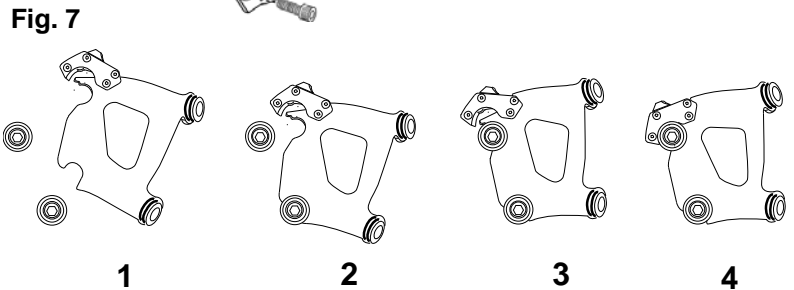
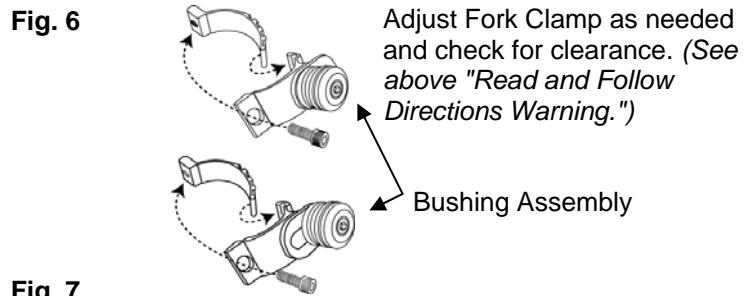
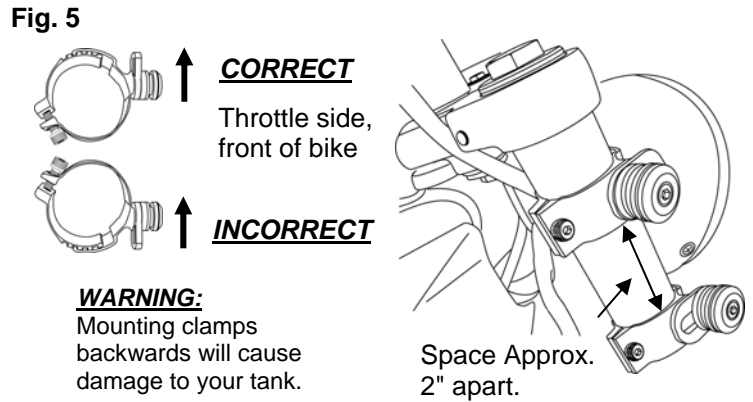
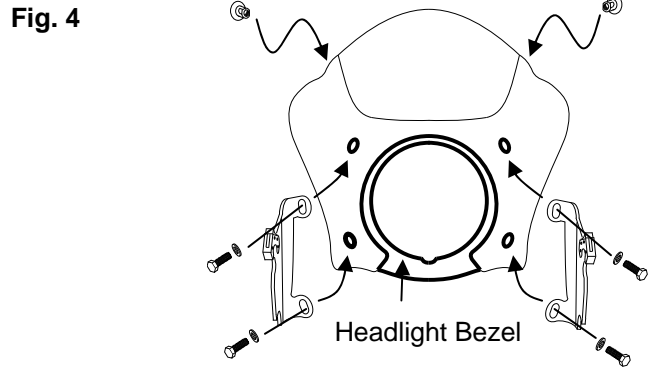
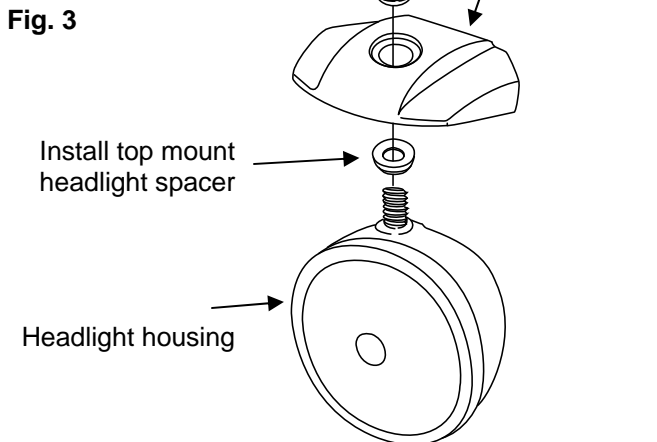
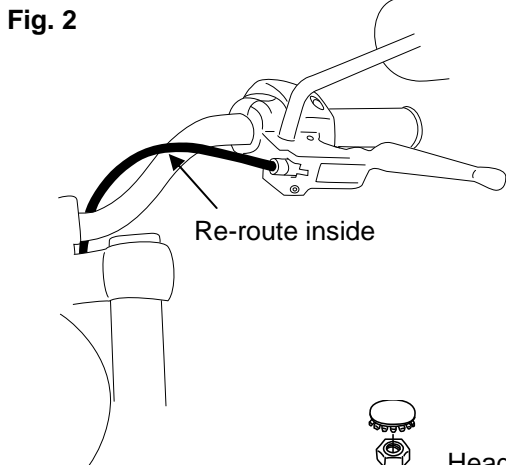
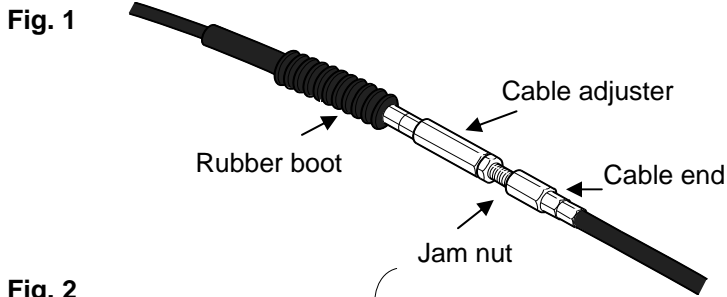

1. Place lower slot into lower bushing.
2. Rotate top slot into place.
3. Secure locking Mechanism.
4. Loosen Allen Bolt to adjust angle, then re-tighten Allen Bolt.

