



Part No. 2321-0303

MEK1980

REVISION 0

MS Fork Deflectors
78mm—86mm Covered forks
Mounting kit

Use to install your MS Fork Deflector plastic

Before assembly, read Warnings inside



WARNING

1. During installation, make sure that the fork deflector and hardware do not interfere with any cables or wiring when the forks are turned all the way in either direction. Also make sure, through the full range of adjustment, that the fork deflector and hardware do not hit the gas tank or fender
2. The improper installation of this kit and related components could result in serious injury or death.



CAUTION

1. Memphis Shades fork deflectors are made from Lucite® acrylic, and will last for years with proper care. Clean your fork deflector with plenty of soapy water (mild dishwashing liquid is best) and a soft cotton cloth. Use your bare hands to feel and dislodge bugs, or cover with a wet, soapy towel and let it soak. Don't use paper towels and scrape with anything. Small scratches can be removed with NOVUS #2.
2. Never use any glass cleaning products, petroleum based chemicals, or cleaning agents with ammonia, bleach or any other harsh chemicals. This includes (but not limited to) RainX, brake fluid, acetone, paint thinner, benzene and gasoline. "If it hurts your nose, it will hurt the plastic."
3. Glass cleansing agents will cause severe damage to your fork deflector, and will void your warranty.

1. Kit Contents

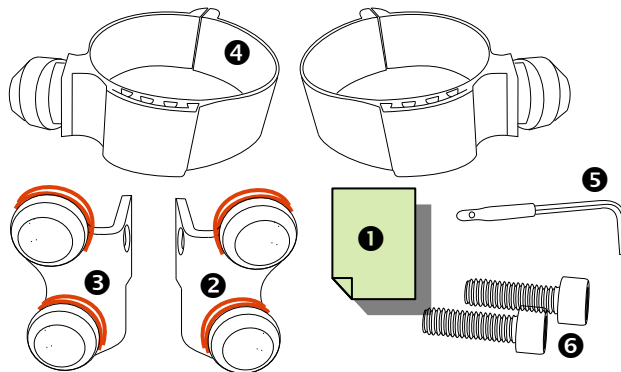

Ref	Code	Description	Qty
①	I1980	Mounting Instructions	1
②	M1382	Throttle side bracket assembly	1
③	M1381	Clutch side bracket assembly	1
④	S1239	Clamp assembly	2
⑤	M310	3/16" Short arm allen wrench	1
⑥	R331	Socket head cap screw, 1/4 20 x 7/8	2

2. Mounting Instructions

Additional tools required, 7/8" wrench.

1. Cover gas tank and front fender with towels to avoid damage during installation.
 2. Attach the Fork deflectors to the Throttle side bracket assembly ② and the Clutch side bracket assembly ③ using the pre-assembled bolts. The Santoprene grommets should be inserted through the holes in the Fork deflectors so that the flat round part of the grommet lies flat on each side of the plastic.
 3. Loosely install the Fork clamp assemblies ④ on each fork. (Fig 1) Additional screws have been provided for some fitments. Use the longer screws ⑥ if the screw seems too short. Be sure the longer screw will not hit your fender, see Figure 2
 4. Remove the bolt and spacer from each clamp, and fit each bracket over the location tab. Replace the spacer and bolt and retighten.
 5. Adjust height and angle, position and tighten all bolts.
- NOTE: Improperly installed fork clamps will cause damage to your motorcycle. Before final installation make sure the Fork deflectors and Clamp assemblies will clear all fenders, radiators, oil coolers, turn signals, gas tank and any other accessories when installed. Turn forks full left and right also apply front brake and rock the bike forward to check for proper clearance with no interference.

Memphis Shades warrants all product components, metal and plastic, against defects in materials and workmanship for 24 months.

For Parts and Warranty Help, Contact:

Memphis Shades, Inc.

P.O. Box 429

Rossville, TN 38066

(901) 853 0293

Visit us on the web at www.memphisshades.com or you can also reach us by email:

customerservice@memphisshades.com

2. Mounting Instructions, continued

Fig. 1

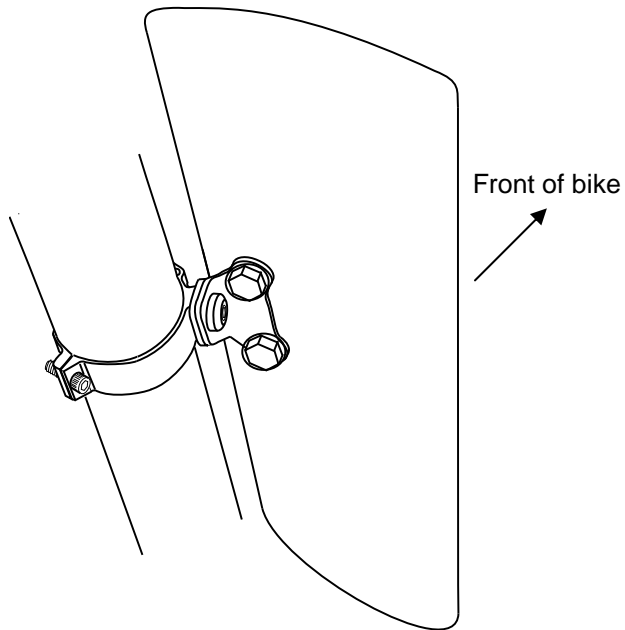

Fig. 2

