



Part No. 2320-0144



MEK2007

REVISION 0

1. Kit Contents

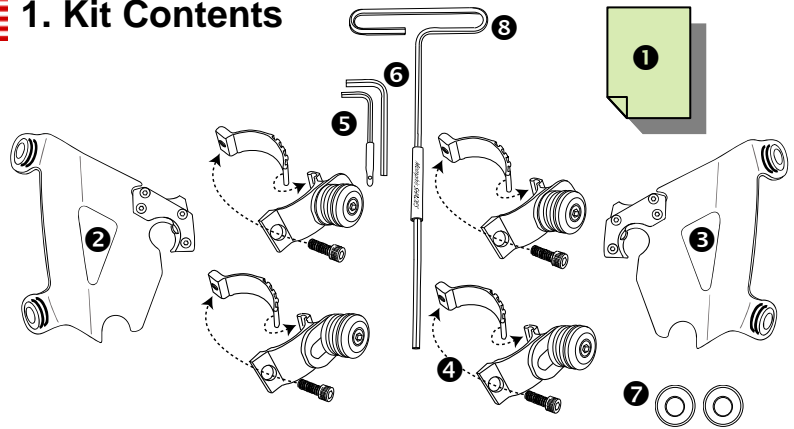

Trigger-Lock Mounting Kit - Polished MS Café Fairing HD XL 1200C Custom 2011– 2014

Aluminum parts are electrocoated (E-coated) for durability and weather resistance.

Before assembly, read Warnings inside



WARNING

1. During installation, make sure that the fairing and hardware do not interfere with any cables or wiring when the forks are turned all the way in either direction. Also make sure , through the full range of adjustment, that the fairing and hardware do not hit the gas tank.
2. This is a detachable fairing, ALWAYS make sure the locking mechanism is fully engaged after installing the fairing.
3. The improper installation of this kit and related components could result in serious injury or death.



CAUTION

1. Memphis Shades fairings are made from Lucite® acrylic, and will last for years with proper care. Clean your fairing with plenty of soapy water (mild dishwashing liquid is best) and a soft cotton cloth. Use your bare hands to feel and dislodge bugs, or cover with a wet, soapy towel and let it soak. Don't use paper towels and scrape with anything. Small scratches can be removed with NOVUS #2.
2. Never use any glass cleaning products, petroleum based chemicals, or cleaning agents with ammonia, bleach or any other harsh chemicals. This includes (but not limited to) RainX, brake fluid, acetone, paint thinner, benzene and gasoline. "If it hurts your nose, it will hurt the plastic."
3. Glass cleansing agents will cause severe damage to your fairing, and will void your warranty. For care and cleaning we recommend using **Memphis Shades All Kleer**, a unique cleaner/polish, bug remover and rain repellent that leaves a super slick surface that makes the next cleaning even easier.
4. At certain times of the day the Sunlight can reflect off the curvature of a fairing and cause extreme heat build-up on motorcycle instruments and instrument panel. Take care when parking. Park facing the sun, place an opaque object over the instruments or adjust the fairing to avoid reflections.

Ref	Code	Description	Qty
①	I2007	Mounting Instructions	1
②	M1596EC	Clutch side mounting plate	1
③	M1597EC	Throttle side mounting plate	1
④	S1215EC	Small detachable clamp assembly	4
⑤	M310	Short arm allen wrench, 3/16	1
⑥	R340	Short arm allen wrench, 1/4	1
⑦	R501	7/8 Spacer washer (Brow spacer)	2
⑧	M314	T-Handle Wrench, 3/16	1

2. Mounting Instructions

Additional tools required that are not included in this kit. 7/16"(11mm) wrench.

1. **Cover gas tank and front fender with towels to avoid damage during installation.**
2. Remove brow retaining bolts, install 7/8 spacer washer (brow spacer) ⑦ then reinstall using original bolts. (Fig. 1)
3. Install the Mounting plate assemblies ② and ③ onto the fairing, using the bolts that are pre-assembled on the Mounting plate assemblies. The Santoprene grommets should be inserted through the holes in the fairing so that the flat round part of the grommet lies flat on each side of the plastic. Tabs point in towards the headlight. (Fig. 2)
4. Loosely install the four Fork Clamps on the forks, approximately 2" apart. (Fig. 3)

Memphis Shades warrants all product components, metal and plastic, against defects in materials and workmanship for 24 months.

For Parts and Warranty Help, Contact:

Memphis Shades, Inc.

P.O. Box 429

Rossville, TN 38066

(901) 853 0293

Visit us on the web at www.memphisshades.com or you can also reach us by email:

customerservice@memphisshades.com

2. Mounting Instructions, continued

5. Fork Clamp Bushings are pre-adjusted to rear of slot. Adjust as needed and check for clearance. (Fig. 3 & 4) (See Warning)

6. Slip the mounting plates and fairing onto the fork clamps, (Fig. 5) while guiding the bezel over the headlight (Fig. 2) and under the brow. Secure the left and right side locking mechanism

7. Adjust the height, angle and alignment of the fairing and tighten **ALL** bolts.

Note: This is a detachable fairing, **ALWAYS** make sure the Locking Mechanism is Fully Engaged after installing the windshield! (Fig 6)

Fig. 1

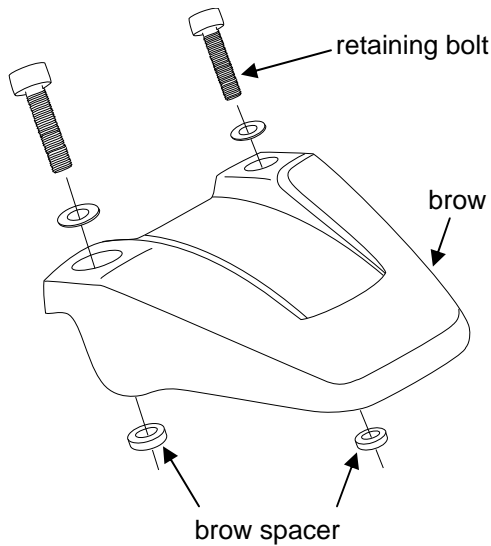

Fig. 2

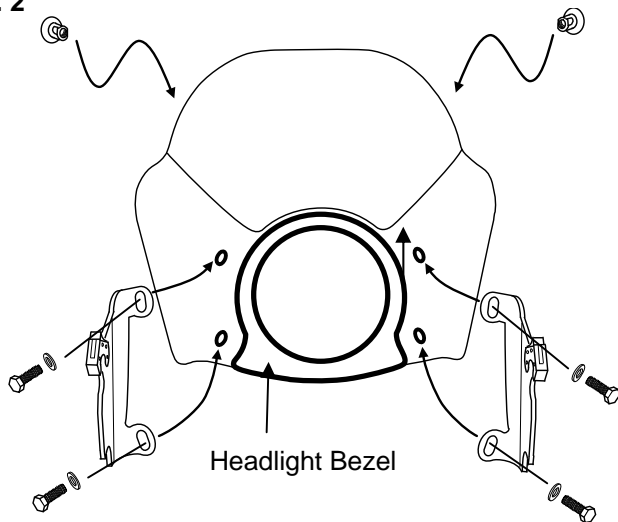

Fig. 3

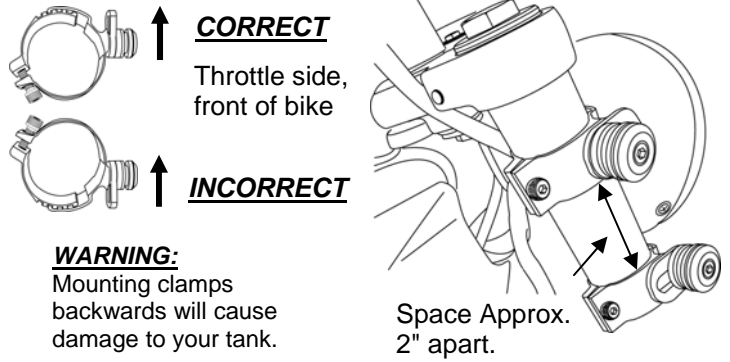

Fig. 4

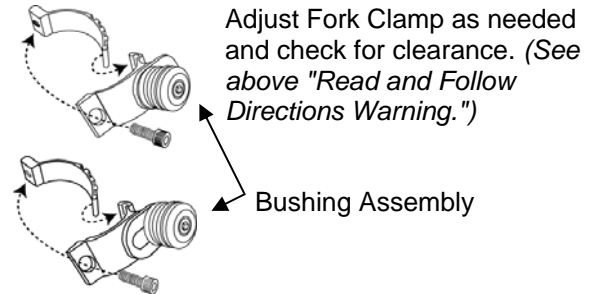
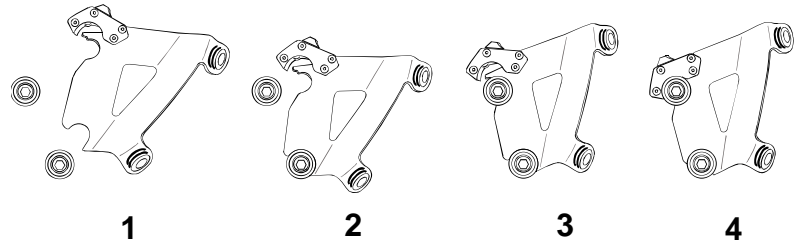

Fig. 5



1. Place lower slot into lower bushing.
2. Rotate top slot into place.
3. Secure locking Mechanism.
4. Loosen Allen Bolt to adjust angle, then re-tighten Allen Bolt.

Fig. 6

Latch assembly

