



Part No. 2320-0113

MEK1983

REVISION 0

**Mounting Kit
Memphis Shades Batwing Fairing
HD Dyna Switchback**

**Aluminum parts are electrocoated (E-coated)
for durability and weather resistance.**

Before assembly, read Warnings inside



WARNING

1. During installation, make sure that the fairing and hardware do not interfere with any cables or wiring when the forks are turned all the way in either direction. Also make sure, through the full range of adjustment, that the fairing and hardware do not hit the gas tank.
2. This is a detachable fairing, ALWAYS make sure the locking mechanism is fully engaged after installing the fairing.
3. The improper installation of this kit and related components could result in serious injury or death.



CAUTION

1. Memphis Shades fairings are made from Lucite® acrylic, and will last for years with proper care. Clean your fairing with plenty of soapy water (mild dishwashing liquid is best) and a soft cotton cloth. Use your bare hands to feel and dislodge bugs, or cover with a wet, soapy towel and let it soak. Don't use paper towels and scrape with anything. Small scratches can be removed with NOVUS #2.
2. Never use any glass cleaning products, petroleum based chemicals, or cleaning agents with ammonia, bleach or any other harsh chemicals. This includes (but not limited to) RainX, brake fluid, acetone, paint thinner, benzene and gasoline. "If it hurts your nose, it will hurt the plastic."
3. Glass cleansing agents will cause severe damage to your fairing, and will void your warranty. For care and cleaning we recommend using **Memphis Shades All Kleer**, a unique cleaner/polish, bug remover and rain repellent that leaves a super slick surface that makes the next cleaning even easier.
4. At certain times of the day the Sunlight can reflect off the curvature of a fairing and cause extreme heat build-up on motorcycle instruments and instrument panel. Take care when parking. Park facing the sun, place an opaque object over the instruments or adjust the fairing to avoid reflections.

1. Kit Contents

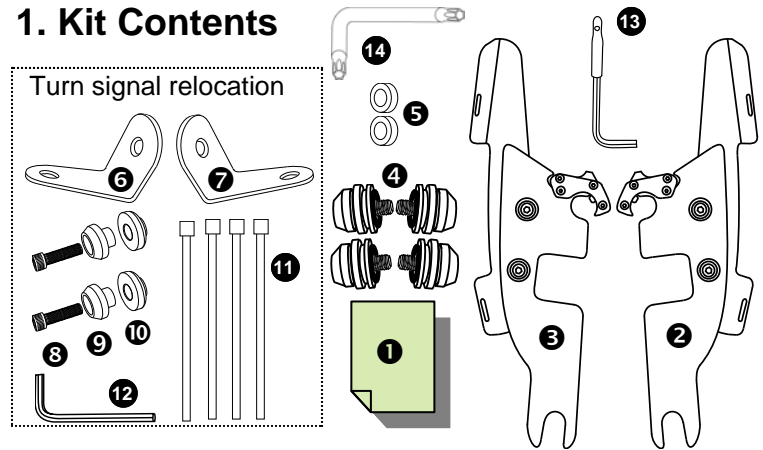

Ref	Code	Description	Qty
①	I1983	Mounting Instructions	1
②	M1571EC	Mounting plate, throttle side	1
③	M1570EC	Mounting plate, clutch side	1
④	S1236EC	Bushing assembly	4
⑤	M1575EC	Spacer	2
⑥	M1201EC	L Bracket, clutch side	1
⑦	M1200EC	L Bracket, throttle side	1
⑧	M332	Socket head cap screw, 5/16 24x7/8	2
⑨	R577EC	Beveled bushing spacer, 7/8	2
⑩	R567EC	Socket shoulder washer	2
⑪	WT100	Wire tie	4
⑫	R340	Short arm allen wrench, 1/4	1
⑬	M310	Short arm allen wrench, 3/16	1
⑭	R360	Short arm torx key, T40	1

2. Mounting Instructions

Additional tools required that are not included in this kit.
7/16 wrench, 1/2 wrench

1. **Cover gas tank and front fender with towels to avoid damage during installation.**
2. Remove the acorn nut and lock washer holding the Turn Signal bracket (Fig 1), and allow the Turn Signal to hang by it's cable. Use the Spacer ⑤ and refit the acorn nut and lock washer.
3. Unscrew the Turn Signal from the bracket (Fig 2).
4. Fit the L Bracket ⑥ or ⑦ onto the Turn Signal using the Socket Shoulder Washer ⑩, Beveled Bushing Spacer ⑨ and Socket head cap screw, 5/16 24x7/8 ⑧ provided (Fig 3).

Memphis Shades warrants all product components, metal and plastic, against defects in materials and workmanship for 24 months.

For Parts and Warranty Help, Contact:

Memphis Shades, Inc.

P.O. Box 429

Rossville, TN 38066

(901) 853 0293

Visit us on the web at www.memphisshades.com or you can also reach us by email:

customerservice@memphisshades.com

2. Mounting Instructions, continued

5. Remove the existing mounts from the forks and replace with the Bushing Assemblies ④ supplied (Fig 4). The Turn Signal, mounted to the L Bracket should be fitted between the Bushing Assembly and the fork spacers on the bike.
6. Install the two Mounting Plates ② and ③ onto the rear of the Fairing using the acorn nuts supplied with the Fairing. The tabs on the Mounting plates should point in, toward the headlight opening. (Fig 5).
7. Slip the Mounting Plates and Fairing onto the Bushing Assemblies and secure in place using the locking mechanism (Fig 6)
8. Adjust the height, angle and alignment of the Fairing and tighten **ALL** bolts.

Note: This is a detachable Fairing, ALWAYS make sure the Locking Mechanism is Fully Engaged after installing the Fairing (Fig 7)

Fig. 1

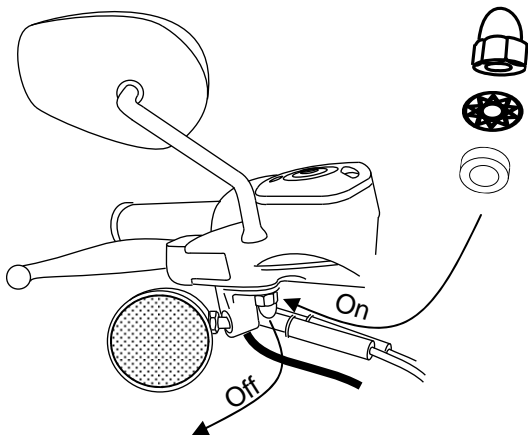

Fig. 2

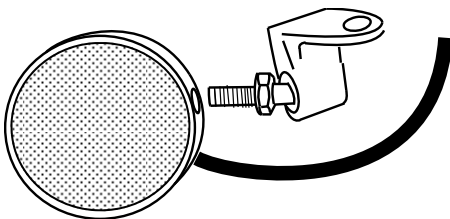

Fig. 3

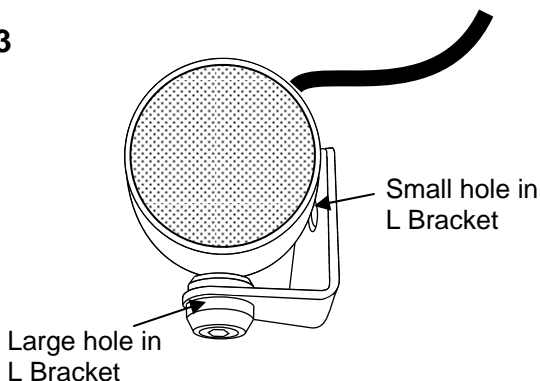

Fig. 4

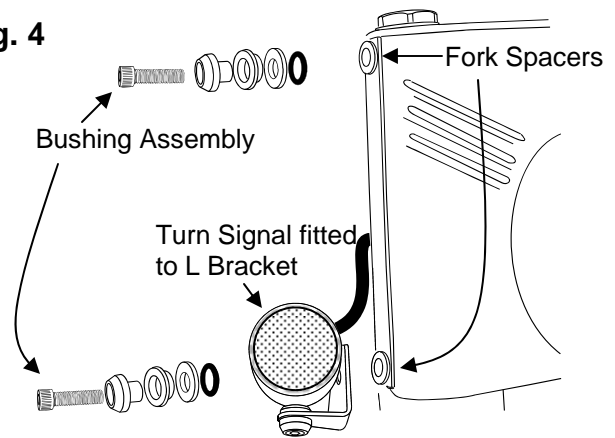

Fig. 5

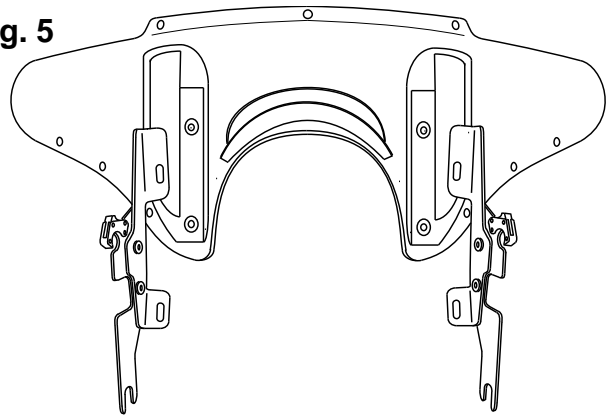
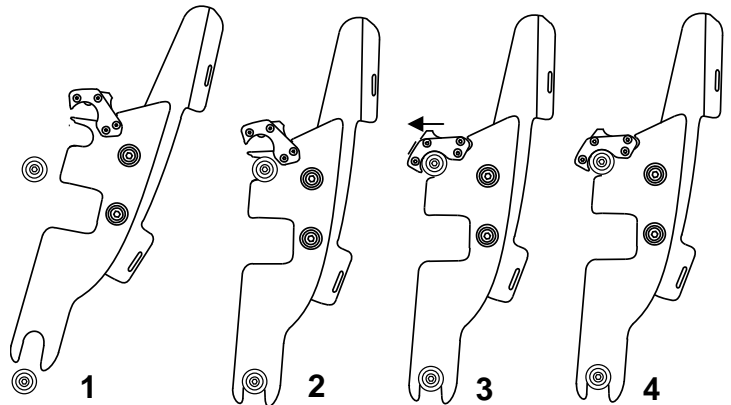

Fig. 6



1. Align the plates with the bushings.
2. Push lower slot into lower bushing.
3. Rotate the plates forward and push the upper slot into the upper bushing.
4. Lock the trigger in place.

Fig. 7

